

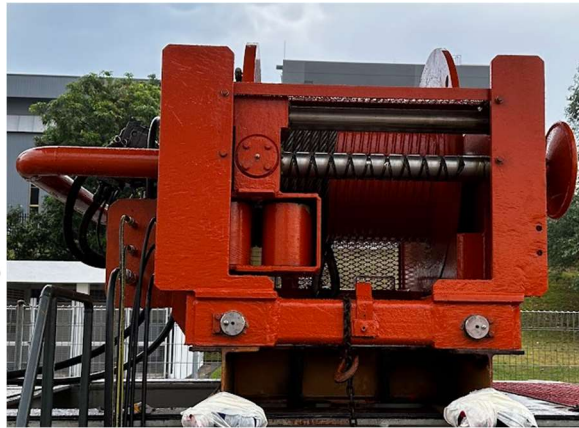

# DATASHEET 20T HYDRAULIC WINCH

Equipment ID: ODEQ-M-WCH-001

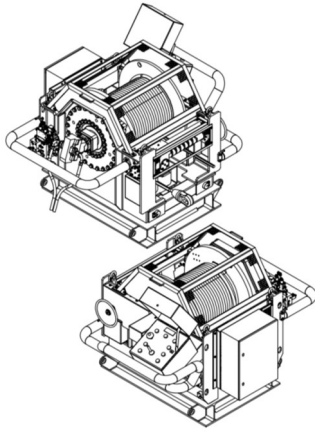

The 20mT SWL hydraulically winch is manually operated. There are no electrical components, the brake and gears are fully enclosed, making the winch suitable to operate in ATEX zone II environment. The winch is fitted with a fail-safe brake, meaning that the brake will always be engaged in case of pressure drop.

Typical use for this winch:

- Riser / umbilical pull-in winch (offshore platforms, zone II areas)
- Deck tugger winch
- Back tension winch (cable / umbilical spooling / tail end)
- A-Frame winch

SPECIFICATIONS			
Winch Dynamic Capacity SWL	20.0	mT	5 <sup>th</sup> (top) layer
	27.0	mT	1 <sup>st</sup> Layer
Winch Static (Brake) Capacity	26.4	mT	5 <sup>th</sup> (top) Layer
	35.6	mT	1 <sup>st</sup> Layer
Speed @ 100% load / flow	16	m/min	HPU 600 L/min
Wire Rope Diameter	32	mm	6x36 IWRC
Dimensions (W x L x H)	2575 x 1655 x 1646	mm	
Weight (W/O wire rope)	4,350	Kg	
Weight (with 32mm, 250m wire rope)	5,600	Kg	1250Kg for wire rope
Weight with Base Frame (no wire)	6,200	Kg	
Hydraulic Working Pressure	230	Bar	270 Bar max pressure
Hydraulic Flow	600	L/min	

OPTIONS:

1. Diesel Driven HPU
2. Control Stand
3. Load Line Monitoring
4. Load Shackles